

ECO7000UND

Product description: underground 7000 water tank

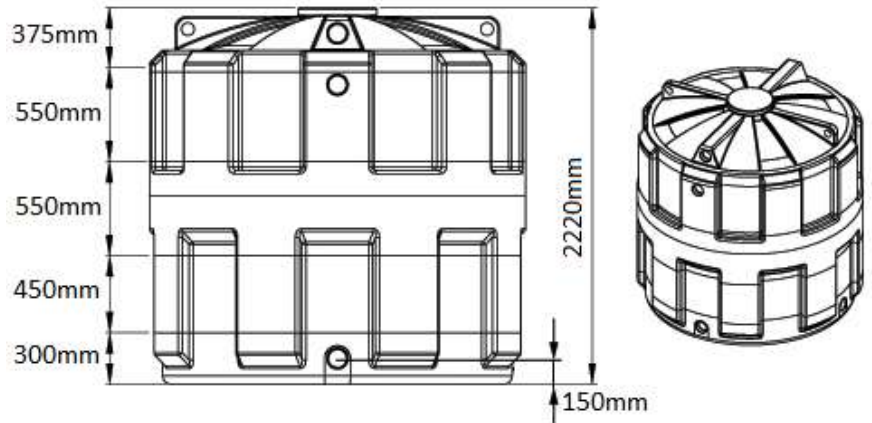

Product Information				
Height	Diameter	Access	Weight	Outlet
2200mm	2150mm	455mm aperture	240kg	Multiple outlet positions to take up to 4" pipe

Sizes approximate, owing to shrinkage

PRODUCT DETAILS:

- Made from virgin polymer
- One piece mould for extra strength
- Designed and manufactured in the UK
- 500mm extended neck included; can be cut down

OPTIONAL EXTRAS:

- Filter box
- Range of pumps
- Tank connectors
- MDPE pipe

BENEFITS:

- Compatible with UK standard 4" (110mm) pipe fittings
- Lifting lugs for easy manoeuvring
- Connect multiple tanks together using 4" drainage pipe
- Rotationally moulded for strength and durability
- 10 year warranty against manufacturing defects

This specification may be subject to change without notice; please call to confirm details.



Etils Ltd
Unit 1 Whiting Way,
Melbourn,
Royston,
SG8 6NA

Tel: 01763 261781
Fax: 01763 268409